

# FEIDER



## AIR CONDITIONER

INSTRUCTION MANUAL  
FCW2600PAP-A  
FCW3500PAP-A



**SODILOG SAS,  
4 RUE CURIE, CS  
91617 68016 COLMAR  
CEDEX FRANCE  
[www.sodilog.com](http://www.sodilog.com)**

**Made in PRC**

**This instruction manual contains important information and recommendations that we ask you to follow in order to get the best possible performance from the air conditioner.**

# CONTENTS

1. SAFETY PRECAUTIONS.....	3
2. NAMES AND FUNCTIONS OF EACH PARTS.....	6
3. DISPLAY ICON.....	7
4. TECHNICAL SPECIFICATIONS.....	8
5. INSTRUCTIONS FOR SERVICING.....	8
6. NOTICE FOR INSTALLATION.....	13
7. INSTALLATION INSTRUCTIONS.....	14
8. USE OF REMOTE CONTROL.....	20
9. CLEANING AND MAINTENANCE.....	24
10. FAULT ANALYSIS.....	26
11. DISPOSAL.....	27
12. DECLARATION OF CONFORMITY.....	28
13. WARRANTY.....	29
14. PRODUCT FAILURE.....	30
15. WARRANTY EXCLUSIONS.....	31









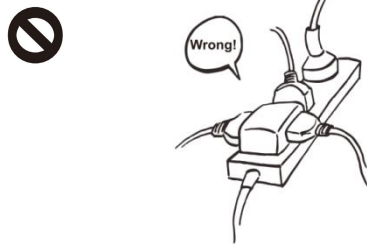
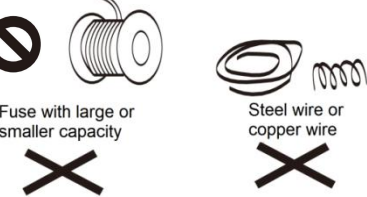
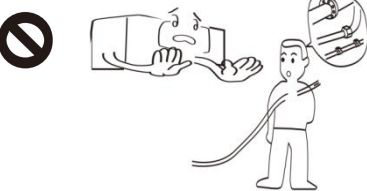

The appliance is in conformity with European Directive 2014/30/EU for EMC, 2014/35/EU for LVD, 2009/125/EC for ERP and 2011/65/EU for Rohs, and comply with the relevant standards.



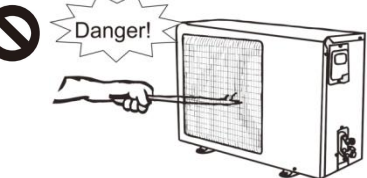

## NOTE:

1. This appliance can be used by children aged from 8 years and above and persons with reduced physical, sensory or mental capabilities or lack of experience and knowledge if they have been given supervision or instruction concerning use of the appliance in a safe way and understand the hazards involved. Children shall not play with the appliance. Cleaning and user maintenance shall not be made by children without supervision.
2. If the supply cord is damaged, it must be replaced by the manufacturer, its service agent or similarly qualified persons in order to avoid a hazard.
3. The appliance shall be installed in accordance with national wiring regulations.
4. How to fixed the appliance to its support please refer to detail information of installation.
5. The design and specifications are subject to change without prior notice for product improvement. Consult with the sales agency or manufacturer for details.
6. The shape and position of buttons and indicators may vary according to the model, but their function are the same.

# 1. SAFETY PRECAUTIONS

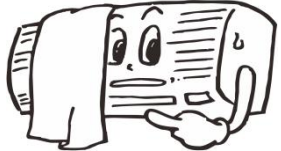
<p><b>N</b>ever use broken or unspecified power cable, power plug and socket. Otherwise it will cause accidents such as electric shock, short circuit.</p>	
<p><b>N</b>ever use the same power socket with other electrical appliances or use too long power cables. Otherwise it will cause fire disaster, electric shock, short circuit, etc</p>	
<p><b>N</b>ever use fuse with improper capacity or other metal fuses. Otherwise it will cause malfunction or fire disaster.</p>	
<p><b>T</b>he air conditioner must be well grounded and the grounding wire should not be connected to the gas pipe, water supply pipe, lightning. Otherwise it will cause accidents.</p>	
<p><b>N</b>ever put air conditioner in the place where the combustible gas may be leaked. Never use it in the environment full of inflammable, explosive and corrosive gases. Otherwise it will cause accidents like fire disaster or explosion.</p>	
<p><b>N</b>ever put chemical spray or paint near the air conditioner or spray. Otherwise it will cause accidents like explosion or fire disaster.</p>	
<p><b>N</b>ever wash air conditioner with water or other fluid, as the water may penetrate into the panel. Otherwise, the internal electrical parts may be damaged.</p>	
<p><b>W</b>hen fan blade is running, do not touch the air outlet of indoor unit and outdoor unit and do not put your hand or any other objects into the grilles. Otherwise it will cause personnel injury or damage to the air conditioner.</p>	
<p><b>N</b>ever let the air conditioner to blow toward the heater appliances. Otherwise it will cause incomplete combustion and gas poisoning.</p>	

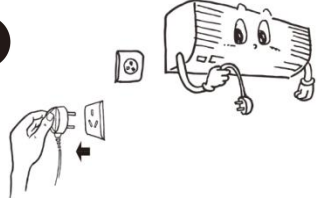
	<b>Do not maintain or repair the air conditioner.</b> Otherwise it will cause electric shock and fire disaster. Please contact our authorized service center to send professional maintenance personnel to repair.
	<b>The place for installation should be capable of load-bearing. If the installation bracket for outdoor unit is broken, do not place air conditioner on it.</b> Otherwise the outdoor unit will be dropped down or fell over and cause personal injury or damage to equipment.
	<b>Do not stand on the outdoor unit or put objects on it.</b> Otherwise people or objects may be fell down and cause personal injury or damage to equipment.
	<b>Do not plug or unplug the power plugs with wet hands and do not operate remote control with wet hands.</b> Otherwise it will damage the electrical appliances or cause electric shock.
	<b>If abnormal conditions are found, such as the burnt smell, stop the air conditioner immediately and cut off power supply.</b> If measures are not taken in time, the air conditioner will be damaged and electric shock or fire disaster may be occurred. Please contact our dealer or service center.
	<b>Make sure the power plug is completely inserted into the socket.</b> If the plug is not completely inserted into the socket, it will cause fire disaster by heating.
	<b>Regularly clean the dust on the power plug.</b> Dust on the power plug and moisture may cause poor insulation and even fire disaster.

<b>Do not block the air inlet and outlet of indoor unit and outdoor unit.</b> Otherwise it will influence the function of air conditioner and even machine halt.	 
<b>If the air conditioner is not used for a long time or it is to clean the air conditioner, please disconnect the power supply.</b> Otherwise it will cause personal injury or damage to the air conditioner.	 
<b>Do not blow the cold air at human body for a long time and do not cool down the room temperature too low.</b> Or it will do harm to your health.	 

	<b>Do not use the air conditioner for the precision equipment, animals, plants, foods or art works.</b> Otherwise it will cause harmful effect.
	<b>Do not directly blow at children, animals and plants.</b> Otherwise it will do harm to them.
	<b>Do not put the objects, which need to avoid moisture, under the indoor unit and outdoor unit.</b> Sometimes the moisture in the air will be condensed as water-drop, thus damaging the objects which need to avoid moisture.

	<b>Do not touch the aluminum parts of indoor unit or outdoor unit of air conditioner.</b> Sharp aluminum sheet may cause personnel injury.
	<b>Tubing for the drain hose should ensure the good drainage.</b> In case of bad tubing, the water will penetrate into the room and moisten the items in the room.
	<b>Frequently ventilate.</b> Insufficient ventilation will cause oxygen deficiency and headache. If the air conditioner is used simultaneously with the gas burning appliances, please remember to keep good ventilation.
	<b>During air conditioning refrigeration, reduce the heat in the room and keep away the sun light and hot wind.</b> Otherwise it will influence the refrigeration effect.
	<b>If the air conditioner is to be used when the season changes, please remember to remove the hood.</b> If the hood is not removed before operation, the outdoor unit will be in poor heat dissipation and the compressor will stop running and even be damaged.

### **Temperature Conditions**

In the following temperature range, the air conditioning protective equipment will run and the air conditioner will stop. As a result, to ensure the normal operation of air conditioner, the following temperature conditions should be avoided.

Heating	Outdoor temperature -5~24 °C	Refrigerating	Outdoor temperature 21~43 °C
	Room temperature 20~27 °C		Room temperature 21~32 °C

If the power is not cut off, and the machine is started immediately after stoppage or the mode is changed during operation, the protective device in the unit will work. The air condition compressor has to wait for 3 minutes to start running.

### **Features in Heating Operation** (for both cooling and heating equipment)

#### **Pre-heating:**

After heating is started, the indoor unit will be pre-heated for 2 to 5 minutes. After pre-heating temperature is low, the electric heating will be process, the warm air comes out. When the room activated. (for the cooling and heating equipment with auxiliary heater)

#### **Defrosting:**

During heating process, if the outdoor unit is frosted, the air conditioner will perform auto defrosting to enhance the heating effect. During will stop. After defrosting is finished, the heating defrosting, the fans of both indoor and outdoor unit process is recovered.

### **Inspection before operation**

Newly installed air conditioner	<ol style="list-style-type: none"> <li>1. Check if the installation is reasonable;</li> <li>2. Check if the batteries are installed in the remote controller;</li> <li>3. Check if the power supply is connected.</li> </ol>
---------------------------------	--





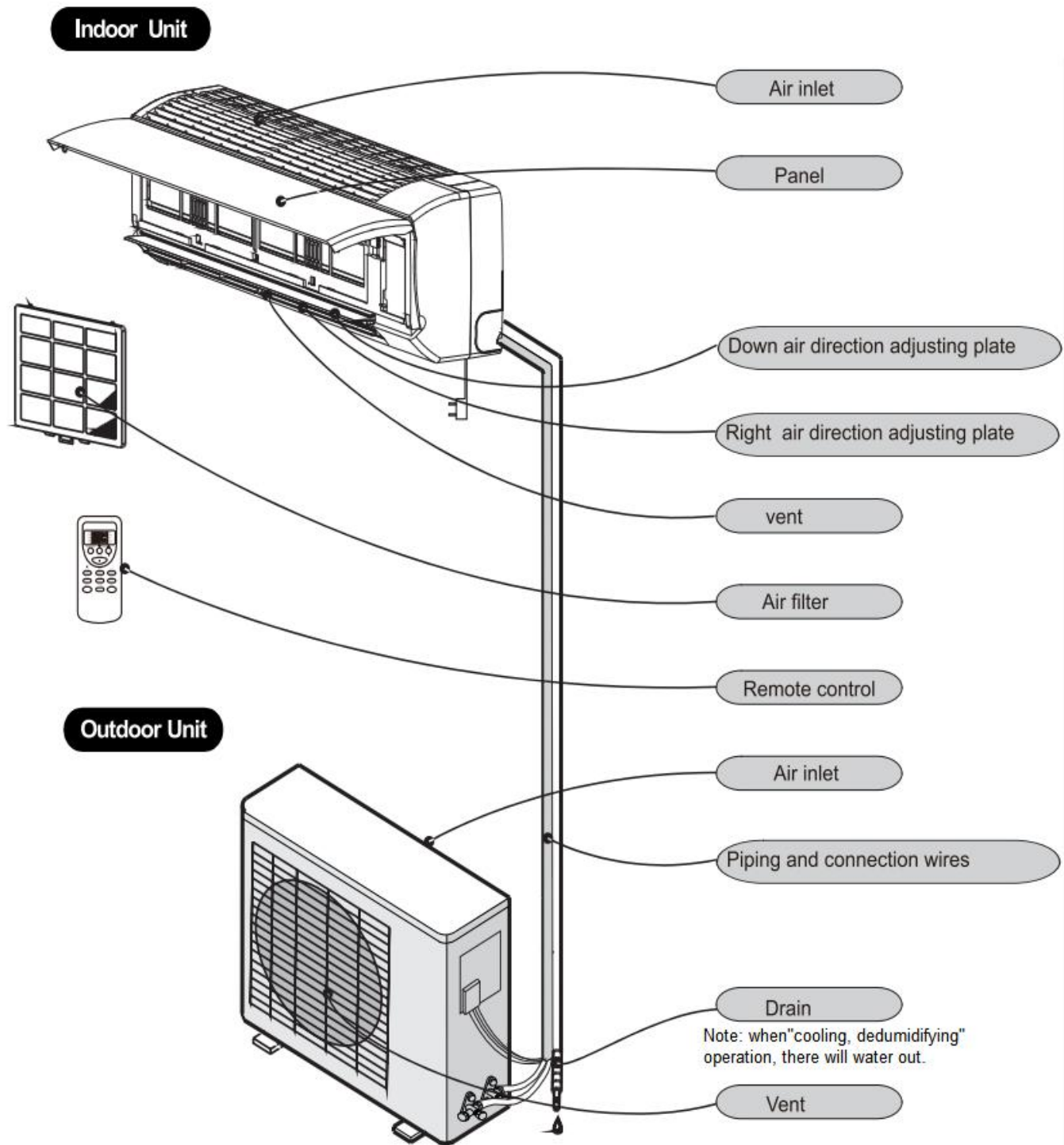









## 2. NAMES AND FUNCTIONS OF EACH PARTS

Because there are many models, features and appearance will vary, we only introduce the following.



NOTE: The picture shows the structure diagram, rather than the product.

### 3. DISPLAY ICON

Running indicator	
Timer indicator	
Sleeping indicator	
Cooling indicator	
Heating indicator	
Dehumidifying indicator	
Ventilation run icon	
Auto indication icon	
Low wind run icon	
Stroke run icon	
The high wind run icon	
Strong run icon	
Digital display tube icon	
Electric heating run icon	



Above figure shows all indications for the purpose of the explanation but practically only the pertinent parts are indicated.



The indicator may be changed, but it does not affect your operation.

NOTE: You can check product parameters from the nameplate.

## 4. TECHNICAL SPECIFICATIONS

Refer to the technical label located on the outdoor unit.

 	
<b>CLIMATISEUR MURAL</b>	
Modèle de produit	FCW2600PAP-A
Modèle d'unité extérieure	FCW2600PAP-A
Electric Shock Prevention	class I
Type de climat	T1
Tension nominale	220-240V~
Fréquence nominale	50Hz
Puissance froid nominale	752W
Puissance chaud nominale	736W
Courant d'entrée max.	8.3A
Pression de refoulement max.	4.2MPa
Pression d'aspiration max.	1.2MPa
Réfrigérant	R32
Quantité de réfrigérant	0.31kg/0.21t CO2eq
Classe d'imperméabilité	IPX4
Extérieure Poids	25kg
S/N: BUILDER SAS 32 rue Aristide Bergès - Z.I. du Casque - 31270 Cugnaux - France MADE IN PRC	





 	
<b>CLIMATISEUR MURAL</b>	
Modèle de produit	FCW3500PAP-A
Modèle d'unité extérieure	FCW3500PAP-A
Electric Shock Prevention	class I
Type de climat	T1
Tension nominale	220-240V~
Fréquence nominale	50Hz
Puissance froid nominale	1020W
Puissance chaud nominale	992W
Courant d'entrée max.	8.3A
Pression de refoulement max.	4.2MPa
Pression d'aspiration max.	1.2MPa
Réfrigérant	R32
Quantité de réfrigérant	0.45kg/0.30t CO2eq
Classe d'imperméabilité	IPX4
Extérieure Poids	27kg
S/N: BUILDER SAS 32 rue Aristide Bergès - Z.I. du Casque - 31270 Cugnaux - France MADE IN PRC	

## 5. INSTRUCTIONS FOR SERVICING

### 1. Qualification requirement for installation and maintenance man

All the work men who are engaging in the refrigeration system should bear the valid certification awarded by the authoritative organization and the qualification for dealing with the refrigeration system recognized by this industry. If it needs other technician to maintain and repair the appliance, they should be supervised by the person who bears the qualification for using the flammable refrigerant.

It can only be repaired by the method suggested by the equipment' s manufacturer.

	warning; flammable material.		Operator's manual.
	Read operator's manual.		Service indicator; Read technical manual.

**⚠ WARNING!** Do not use means to accelerate the defrosting process or to clean, other than those recommended by the manufacturer.

- The appliance shall be stored in a room without continuously operating ignition sources (for example: open flames, an operating gas appliance or an operating electric heater).
- Do not pierce or burn.

- Be aware that refrigerants might not contain an odour.
- The installation of pipe-work shall be kept to a minimum.
- The pipe-work shall be protected from physical damage and shall not be installed in an unventilated space.
- The compliance with national gas regulations shall be observed;
- The mechanical connections made shall be accessible for maintenance purposes;
- Combustible refrigerants should be placed in sealed containers, and waste refrigerants should be recycled and disposed of Avoiding adverse effects on the environment.
- Keep any required ventilation openings clear of obstruction
- Servicing shall be performed only as recommended by the manufacturer.

## **2. Information on servicing**

### 1) Checks to the area

Prior to beginning work on systems containing flammable refrigerants, safety checks are necessary to ensure that the risk of ignition is minimized. For repair to the refrigerating system, the following precautions shall be complied with prior to conducting work on the system.

### 2) Work procedure

Work shall be undertaken under a controlled procedure so as to minimize the risk of a flammable gas or vapor being present while the work is being performed.

### 3) General work area

All maintenance staff and others working in the local area shall be instructed on the nature of work being carried out. Work in confined spaces shall be avoided. The area around the workspace shall be sectioned off. Ensure that the conditions within the area have been made safe by control of flammable material

### 4) Checking for presence of refrigerant

The area shall be checked with an appropriate refrigerant detector prior to and during work, to ensure the technician is aware of potentially flammable atmospheres. Ensure that the leak detection equipment being used is suitable for use with flammable refrigerants, i.e. non-sparking, adequately sealed or intrinsically safe.

### 5) Presence of fire extinguisher

If any hot work is to be conducted on the refrigeration equipment or any associated parts, appropriate fire extinguishing equipment shall be available to hand. Have a dry powder or CO<sub>2</sub> fire extinguisher adjacent to the charging area.

### 6) No ignition sources

No person carrying out work in relation to a refrigeration system which involves exposing any pipe work shall use any sources of ignition in such a manner that it may lead to the risk of fire or explosion. All possible ignition sources, including cigarette smoking, should be kept sufficiently far away from the site of installation, repairing, removing and disposal, during which refrigerant can possibly be released to the surrounding space. Prior to work taking place, the area around the equipment is to be surveyed to make sure that there are no flammable hazards or ignition risks. No Smoking signs shall be displayed.

### 7) Ventilated area

Ensure that the area is in the open or that it is adequately ventilated before breaking into the system or conducting any hot work. A degree of ventilation shall continue during the period that the work is carried out.

The ventilation should safely disperse any released refrigerant and preferably expel it externally into the atmosphere.

### 8) Checks to the refrigeration equipment

Where electrical components are being changed, they shall be fit for the purpose and to the correct specification. At all times the manufacturer's maintenance and service guidelines shall be followed.

If in doubt consult the manufacturer's technical department for assistance.

The following checks shall be applied to installations using flammable refrigerants:

- The charge size is in accordance with the room size within which the refrigerant containing parts are installed;
- The ventilation machinery and outlets are operating adequately and are not obstructed;
- If an indirect refrigerating circuit is being used, the secondary circuit shall be checked for the presence of refrigerant;
- Marking to the equipment continues to be visible and legible. Markings and signs that are illegible shall be corrected;
- Refrigeration pipe or components are installed in a position where they are unlikely to be exposed to any substance which may corrode refrigerant containing components, unless the components are constructed of materials which are inherently resistant to being corroded or are suitably protected against being so corroded.

#### 9) Checks to electrical devices

Repair and maintenance to electrical components shall include initial safety checks and component inspection procedures. If a fault exists that could compromise safety, then no electrical supply shall be connected to the circuit until it is satisfactorily dealt with. If the fault cannot be corrected immediately but it is necessary to continue operation, an adequate temporary solution shall be used. This shall be reported to the owner of the equipment so all parties are advised.

Initial safety checks shall include:

- That capacitors are discharged: this shall be done in a safe manner to avoid possibility of sparking;
- That there no live electrical components and wiring are exposed while charging, recovering or purging the system;
- That there is continuity of earth bonding.

### 3. Repairs to sealed components

- 1) During repairs to sealed components, all electrical supplies shall be disconnected from the equipment being worked upon prior to any removal of sealed covers, etc. If it is absolutely necessary to have an electrical supply to equipment during servicing, then a permanently operating form of leak detection shall be located at the most critical point to warn of a potentially hazardous situation.
- 2) Particular attention shall be paid to the following to ensure that by working on electrical components, the casing is not altered in such a way that the level of protection is affected. This shall include damage to cables, excessive number of connections, terminals not made to original specification, damage to seals, incorrect fitting of glands, etc. Ensure that apparatus is mounted securely. Ensure that seals or sealing materials have not degraded such that they no longer serve the purpose of preventing the ingress of flammable atmospheres. Replacement parts shall be in accordance with the manufacturer's specifications.

NOTE: The use of silicon sealant may inhibit the effectiveness of some types of leak detection equipment. Intrinsically safe components do not have to be isolated prior to working on them.

### 4. Repair to intrinsically safe components

Do not apply any permanent inductive or capacitance loads to the circuit without ensuring that this will not exceed the permissible voltage and current permitted for the equipment in use.

Intrinsically safe components are the only types that can be worked on while live in the presence of a flammable atmosphere. The test apparatus shall be at the correct rating. Replace components only with parts specified by the manufacturer. Other parts may result in the ignition of refrigerant in the atmosphere from a leak.

### 5. Cabling

Check that cabling will not be subject to wear, corrosion, excessive pressure, vibration, sharp

edges or any other adverse environmental effects. The check shall also take into account the effects of aging or continual vibration from sources such as compressors or fans.

## **6. Detection of flammable refrigerants**

Under no circumstances shall potential sources of ignition be used in the searching for or detection of refrigerant leaks. A halide torch (or any other detector using a naked flame) shall not be used.

## **7. Leak detection methods**

The following leak detection methods are deemed acceptable for systems containing flammable refrigerants.

Electronic leak detectors shall be used to detect flammable refrigerants, but the sensitivity may not be adequate, or may need re-calibration. (Detection equipment shall be calibrated in a refrigerant-free area). Ensure that the detector is not a potential source of ignition and is suitable for the refrigerant used. Leak detection equipment shall be set at a percentage of the LFL of the refrigerant and shall be calibrated to the refrigerant employed and the appropriate percentage of gas (25 % maximum) is confirmed. Leak detection fluids are suitable for use with most refrigerants but the use of detergents containing chlorine shall be avoided as the chlorine may react with the refrigerant and corrode the copper pipe-work. If a leak is suspected, all naked flames shall be removed/ extinguished. If a leakage of refrigerant is found which requires brazing, all of the refrigerant shall be recovered from the system, or isolated (by means of shut off valves) in a part of the system remote from the leak. Oxygen free nitrogen (OFN) shall then be purged through the system both before and during the brazing process.

## **8. Removal and evacuation**

When breaking into the refrigerant circuit to make repairs or for any other purpose conventional procedures shall be used. However, it is important that best practice is followed since inflammability is a consideration. The following procedure shall be adhered to:

- Remove refrigerant;
- Purge the circuit with inert gas;
- Evacuate;
- Purge again with inert gas;
- Open the circuit by cutting or brazing.

The refrigerant charge shall be recovered into the correct recovery cylinders. The system shall be flushed with OFN to render the unit safe. This process may need to be repeated several times.

Compressed air or oxygen shall not be used for this task.

Flushing shall be achieved by breaking the vacuum in the system with OFN and continuing to fill until the working pressure is achieved, then venting to atmosphere, and finally pulling down to a vacuum. This process shall be repeated until no refrigerant is within the system. When the final OFN charge is used, the system shall be vented down to atmospheric pressure to enable work to take place. This operation is absolutely vital if brazing operations on the pipe-work are to take place.

Ensure that the outlet for the vacuum pump is not close to any ignition sources and there is ventilation available.

## **9. Charging procedures**

In addition to conventional charging procedures, the following requirements shall be followed.

- Ensure that contamination of different refrigerants does not occur when using charging equipment. Hoses or lines shall be as short as possible to minimise the amount of refrigerant contained in them.
- Cylinders shall be kept in an appropriate position according to the instructions.
- Ensure that the refrigerating system is earthed prior to charging the system with refrigerant.
- Label the system when charging is complete (if not already).
- Extreme care shall be taken not to overfill the refrigerating system.

Prior to recharging the system, it shall be pressure-tested with the appropriate purging gas. The system shall be leak-tested on completion of charging but prior to commissioning. A follow up leak test shall be carried out prior to leaving the site.

## **10. Decommissioning**

Before carrying out this charging procedures, it is essential that the technician is completely familiar with the equipment and all its detail. It is recommended good practice that all refrigerants are recovered safely. Prior to the task being carried out, an oil and refrigerant sample shall be taken in case analysis is required prior to re-use of reclaimed refrigerant. It is essential that electrical power is available before the task is commenced. In addition to conventional charging procedures, the following requirements shall be followed.

- a) Become familiar with the equipment and its operation.
- b) Isolate system electrically.
- c) Before attempting the procedure, ensure that:
  - mechanical handling equipment is available, if required, for handling refrigerant cylinders;
  - all personal protective equipment is available and being used correctly;
  - the recovery process is supervised at all times by a competent person;
  - recovery equipment and cylinders conform to the appropriate standards.
- d) Pump down refrigerant system, if possible.
- e) If a vacuum is not possible, make a manifold so that refrigerant can be removed from various parts of the system.
- f) Make sure that the cylinder is situated on the scales before recovery takes place.
- g) Start the recovery machine and operate in accordance with manufacturer's instructions.
- h) Do not overfill cylinders. (No more than 80 % volume liquid charge).
- i) Do not exceed the maximum working pressure of the cylinder, even temporarily.
- j) When the cylinders have been filled correctly and the process completed, make sure that the cylinders and the equipment are removed from site promptly and all isolation valves on the equipment are closed off.
- k) Recovered refrigerant shall not be charged into another refrigeration system unless it has been cleaned and checked.

## **11. Labelling**

Equipment shall be labelled stating that it has been de-commissioned and emptied of refrigerant. The label shall be dated and signed. For appliances containing flammable refrigerants, ensure that there are labels on the equipment stating the equipment contains flammable refrigerant.

## **12. Recovery**

When removing refrigerant from a system, either for servicing or decommissioning, it is recommended good practice that all refrigerants are removed safely.

When transferring refrigerant into cylinders, ensure that only appropriate refrigerant recovery cylinders are employed. Ensure that the correct number of cylinders for holding the total system charge is available. All cylinders to be used are designated for the recovered refrigerant and labelled for that refrigerant (i.e. special cylinders for the recovery of refrigerant). Cylinders shall be complete with pressure-relief valve and associated shut-off valves in good working order. Empty recovery cylinders are evacuated and, if possible, cooled before recovery occurs.

The recovery equipment shall be in good working order with a set of instructions concerning the equipment that is at hand and shall be suitable for the recovery of all appropriate refrigerants including, when applicable, flammable refrigerants. In addition, a set of calibrated weighing scales shall be available and in good working order. Hoses shall be complete with leak-free disconnect couplings and in good condition. Before using the recovery machine, check that it is in satisfactory working order, has been properly maintained and that any associated electrical components are sealed to prevent ignition in the event of a refrigerant release. Consult manufacturer if in doubt.

The recovered refrigerant shall be returned to the refrigerant supplier in the correct recovery

cylinder, and the relevant waste transfer note arranged. Do not mix refrigerants in recovery units and especially not in cylinders.

If compressors or compressor oils are to be removed, ensure that they have been evacuated to an acceptable level to make certain that flammable refrigerant does not remain within the lubricant. The evacuation process shall be carried out prior to returning the compressor to the suppliers. Only electric heating to the compressor body shall be employed to accelerate this process. When oil is drained from a system, it shall be carried out safely.

## 6. NOTICE FOR INSTALLATION

### INSTALLATION ENVIRONMENT

The air conditioner must be installed by professionals. The "Installation Instructions" is only for the reference of professional installation personnel! The installation must conform to our after-sale service regulations.

#### 1. Requirements for installation environment of indoor unit

- Install on the non-vibration and solid wall and make horizontal adjustment. Put the back of wall-hanging unit against the wall.
- There are no obstacles prevent the proper air circulation at air inlet and outlet.
- Keep away from the heat source and inflammables and places where the moisture is strong.
- The panel of the indoor unit should avoid being exposed to sunlight. The operation location should not have strong electromagnetic interference.
- It should be convenient for connecting the outdoor unit and draining through drain hose.
- It should be near to the power socket for dedicated line.
- Install by following the instructions on the diagram to ensure the distance between the unit and wall, ceiling, and other obstacles, so as to ensure the normal operation and maintenance of unit.
- Height of the indoor unit to the floor should be higher than the sight level.



#### 2. Requirements for installation environment of outdoor unit

- Installation foundation should be solid and firm.
- Install by following the instructions in the diagram to ensure the distance between the unit and other obstacles.
- It should add weather-proof and sunshade shelter to prevent the outdoor unit from being damaged by rain and sunlight. Be careful not to influence the heat dissipation.
- Keep away from the heat source and inflammables.
- It should install in a proper place to prevent the operation noise and circulated gas of outdoor unit from influencing the neighbors.

### Notices for Installation

- The fuse types for the series of indoor unit include 50T or 50F and the rated parameter is T3.15A 250V. No fuse is equipped on the machine. Please select proper fuses or other over-current protective equipment for power supply in accordance with the requirements on the main nameplate.
- The series of air conditioners can be safely used under the external static pressure of 0.8-1.05 times of standard atmospheric pressure.
- The air conditioner should be installed in accordance with national wiring rules.
- Please check if the electric circuit connection, electric wires, electric meter, fuses, sockets, and switches for air conditioners conform to the national electrical safety standards. Make sure there is good grounding protection. Grounding wire must not be connected to the water supply pipe, gas pipe and other unreliable places. (Note: Installation and connection of electrical equipment should be performed by qualified professional technical personnel holding electrician certificate so as to avoid accidents).

- Please check if the power supply for air conditioner conforms to the requirements of national standards: AC 50Hz 220V-240 ± 10%, It is the basic requirement for the safe and long-term use of your air conditioner.

	<p><b>When installing or handling the air conditioner, no other gases except for specified refrigerant is allowed to mix in the refrigerant pipeline system.</b> Otherwise the refrigerating cycle will be in abnormal high pressure and lead to pipe breaking and even personal injury.</p>
	<p><b>The unused power lines should not be tied up with bandage. Keep the lines in the piping tank in the back of the indoor unit.</b> Otherwise it may cause heating and even fire.</p>
	<p><b>Do not process or prolong the power lines and use multiple distribution wires.</b> Otherwise it may cause problems like poor contact, poor insulation and exceeding the permissible current, which may lead to dangerous situations like electric shock, fire, etc.</p>
	<p><b>The connecting terminals for indoor and outdoor units must be firmly connected and fixed with fixed device.</b> Otherwise the terminal connecting position will be heated and cause fire.</p>
	<p><b>The air conditioner must use independent circuit and must be equipped with delay action circuit breaker or auto-circuit breaker.</b> If the air conditioner use shared line with other devices, it may be heated and cause fire.</p>
	<p><b>After installation, check to make sure no refrigerant is leaked, refrigerant system is well sealed and drain hose is unobstructed.</b> Otherwise the refrigerating effect will be influenced and the refrigerant leakage will do harm to human's health.</p>

## 7. INSTALLATION INSTRUCTIONS

Installation Diagram for indoor and outdoor unit

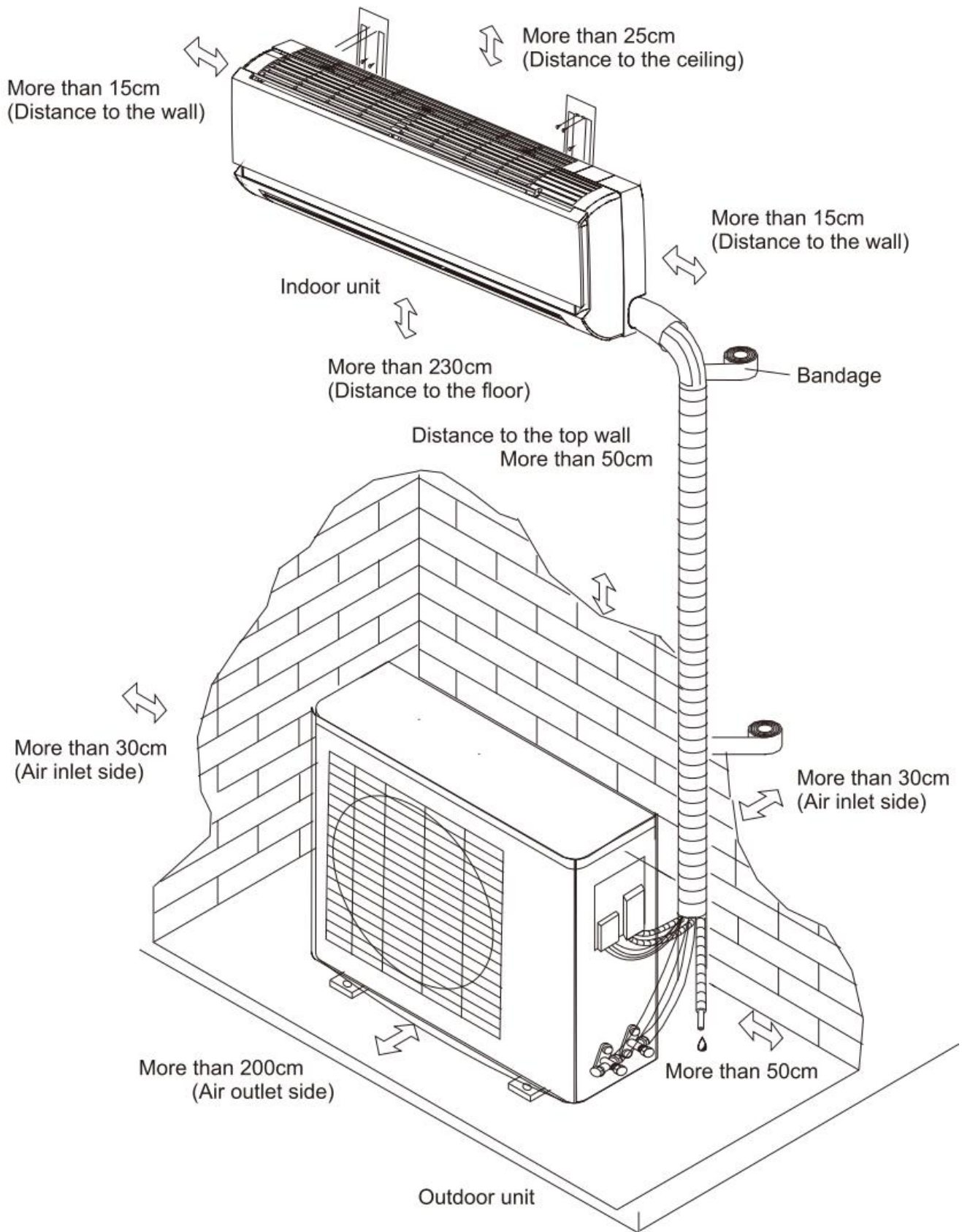

Cooling Capacity	Maximum Height Piping Length(m)	Maximum Height Difference(m)	Additional Refrigerant (g/m)	Piping Length for Adding of Refrigerant(m)
1P/1.5P	10	5	20	4
2P/3P	10	8	30	4

Recommended cable specification

Cooling Capacity	Suggested that type	1P	1.5P/2P	3P
Indoor power cord	H05VV-F	≥1.0mm <sup>2</sup>	≥1.5mm <sup>2</sup>	≥2.5mm <sup>2</sup>
Indoor and outdoor power cord	H07RN	≥1.0mm <sup>2</sup>	≥1.5mm <sup>2</sup>	≥2.5mm <sup>2</sup>
Indoor and outdoor signal line	H05RN	≥0.75mm <sup>2</sup>	≥0.75mm <sup>2</sup>	≥0.75mm <sup>2</sup>

NOTE: This is the schematic diagram and not the product appearance drawing.

 <b>Warning!</b>	<ul style="list-style-type: none"> <li>• When the drainage nozzle is in the right of the indoor unit, as shown above, the left side of the indoor unit should not be 10mm lower and 20mm higher than the right side, so as to ensure the smooth draining of condensed water.</li> <li>• When the drainage nozzle is in the left of the indoor unit, the right side of the indoor unit should not be 10mm lower or 20mm higher than the left side, so as to ensure the smooth draining of condensed water.</li> </ul>
---	--

### Installation of indoor unit

• Mount the wall-hung plate and locate the wall-through hole.

1. Find proper location and adjust the mounting plate horizontally with level meter.
2. By considering the actual situation, the wall-through hole should be made outer part downward a little than the inner part. Insert the wall-through sleeve and put on the cover.
3. Wall-hung plate should be fixed with at least 5 screws. The screws should be distributed evenly.

#### Note:

The number of cables of different air conditioning models will be different, please refer to the electrical diagram for wiring according to the actual number.

#### Steps:

Open the panel, remove the cover plate, and connect the cable correctly as shown in the electrical diagram.

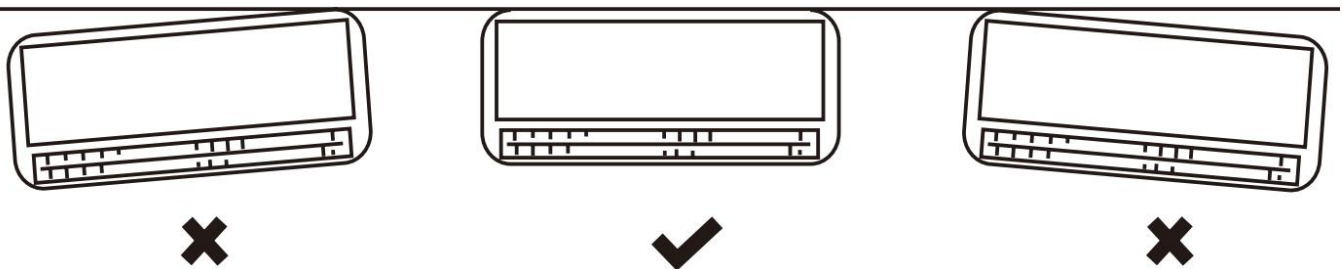
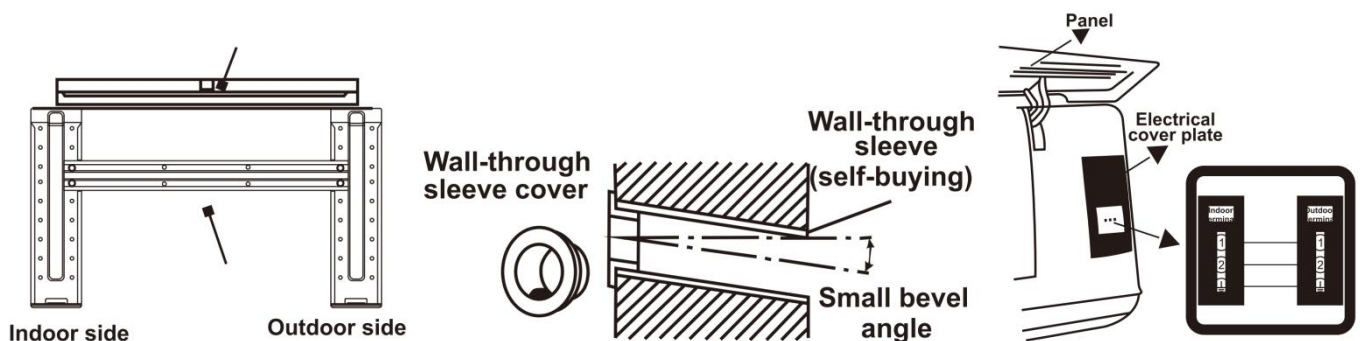

• Arrange pipeline and install the indoor unit

1. Arrange the connecting pipe, drainage pipe and electric wire at bottom to facilitate drainage. Electric wire and indoor & outdoor connecting wire should not be entangled together.

NOTE: Drain hose of indoor unit can only be drawn out from its own side.

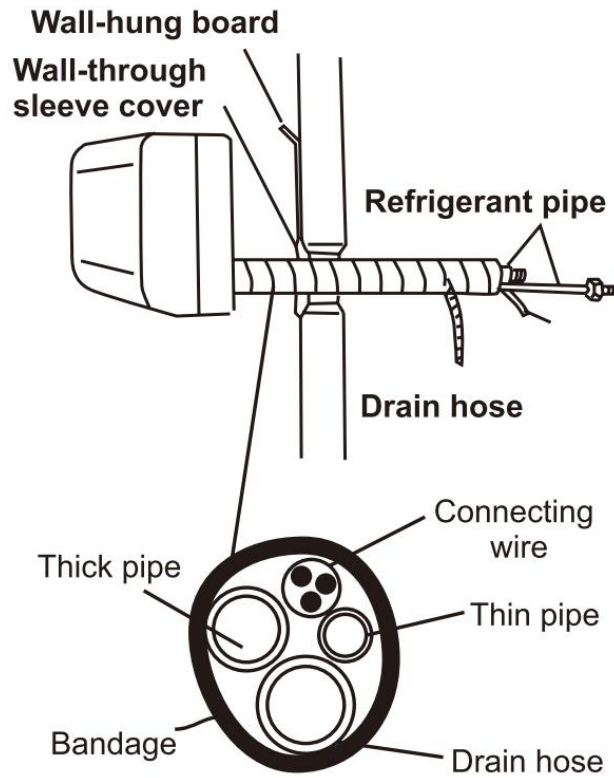

2. Fix the indoor unit on the wall-hung board.

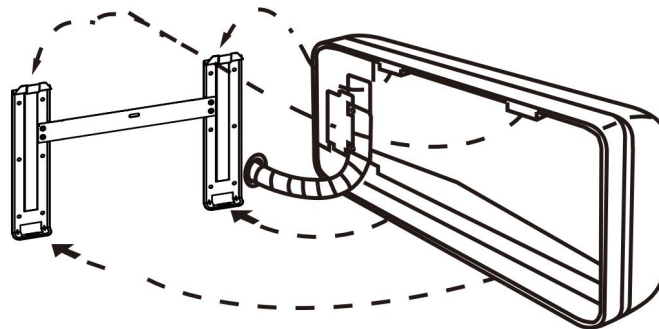

### Installation of outdoor unit

- Installation and fixation

Fix the mounting bracket (to be purchased additionally) on the wall and fix the outdoor unit firmly on the mounting bracket and remain level.

- Connect the electric wire of outdoor unit

1. Loosen the screws of large handle of outdoor unit.

2. Connect the connecting lines of indoor and outdoor units according to the connecting diagram for the large handle.

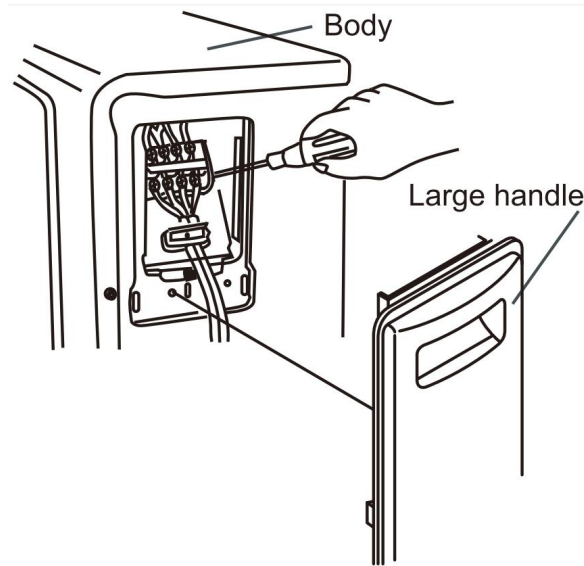

**Warning!** The complete measures must be taken for grounding connection. When the electric wire is suffering the external force, it should ensure the core wires (yellow/green lines) of grounding wire to be stretched after other current-conductor core wires.

**Piping Connection**

• Joint Connection

1. Align with the center of pipe, fasten the screws with hand.
2. Screw the nuts with torque spanner and wrench. Screw according to the instructions of torque spanner. The torque should not be too large or too small.

Diameter of connecting pipe(mm)	Tightening torque of unit(N.m)
6 or 6.35	15-20
9.52	31-35
12 or 12.7	45-50
15.88 or 16	60-65

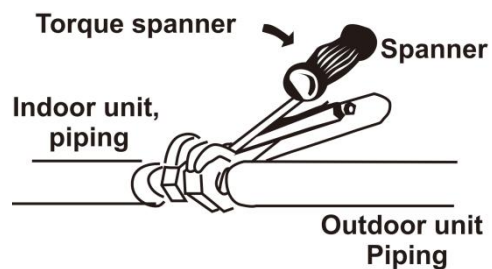
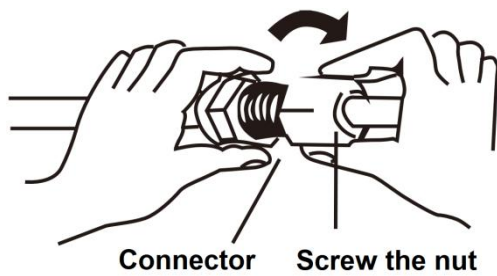

3. Wrap the connector with lagging cover.

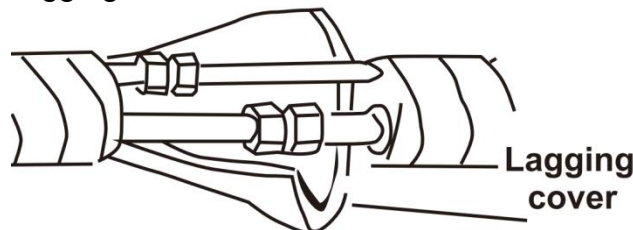

**Operation Method for Exhausting Air**

• Method for exhausting air

1. Remove the nuts on the two-way valve and three-way valve.
2. Turn the valve handle of two-way valve for 90 degree and keep for 10 seconds, and then close.
3. Check the connecting part of pipe with soapy water to see if it leaks air. If no air leakage, open the two-way valve and then close.

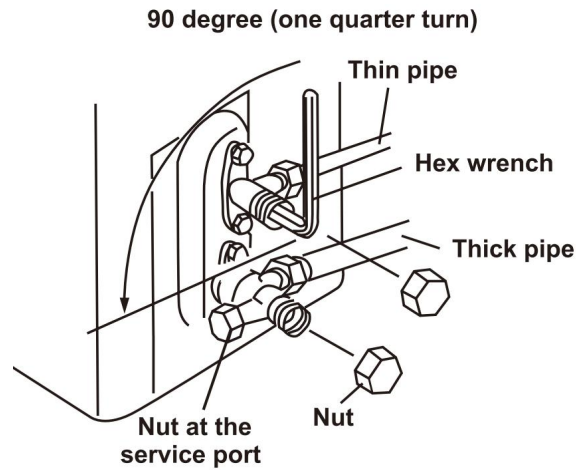

4. During exhausting air, press the pin on the service port of three-way valve with hex wrench for 3 seconds and then release for 1 minute. Open the two-way valve and then close. Repeat the above procedure for 3 times to exhaust air.

5. Open the two-way valve and three-way valve with hex wrench. Screw in the nuts and finish the operation of exhausting air.

• Vacuum method (must be used for R410A refrigerant)

1. Remove the nut on the two-way valve and three-way valve and nut on service port. Connect the low-pressure hose on the dedicated pressure gage to the service port. (The shut-off valve on two-way and three-way valve are in off status)

2. Fully open the low-pressure switch on the pressure gage and start vacuum pump.

3. Vacuumize for at least 25 minutes and make sure the pressure gage indication is  $-0.1\text{MPa}$ . Close the low-pressure switch and then close vacuum pump. If the pressure does not increase within 5minutes, please perform the next operation. Otherwise you should vacuumize again.

4. After vacuumizing, counterclockwise open the shutoff valve on the two-way valve and keep 10 seconds and then stop. Check the leakage (If any leakage is found, reconnect the pipe and then perform the above procedure again).

5. Quickly remove the low-pressure hose and open two-way valve and three-valve with hex wrench.

6. Fasten the nut on the valve body.

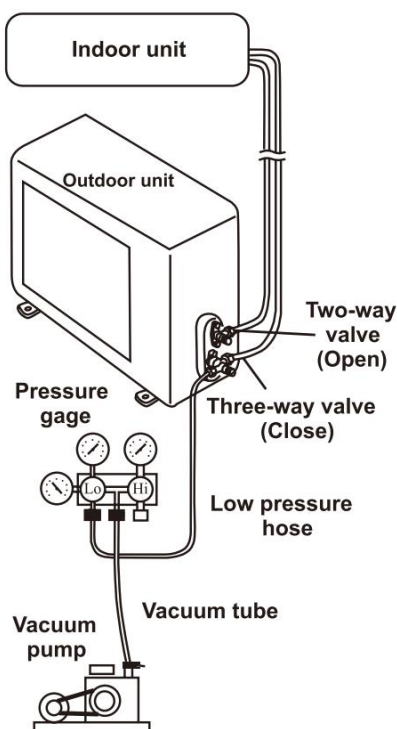

## Inspection after installation

Inspection Items	Problems caused by improper installation
Check if installation is firm	Machine may be fell down, vibrated or made noise
Check if there is any leakage	It may cause insufficiency of cooling (heating) capacity
Check if the heat insulation of machine is sufficient	Condensation or water drop may appear
Check if the drainage is smooth	Condensation or water drop may appear
Check if the power voltage conforms to that on the product nameplate	The machine may be malfunctioned or the parts may be burnt.
Check if the lines and pipes are properly installed.	The machine may be malfunctioned or the parts may be burnt.
Check if the machine is safely grounded.	Electric leakage may occur.
Check if the electric wire type conforms to the specification.	The machine may be malfunctioned or the parts may be burnt.
The air outlet and inlet of indoor and outdoor unit are obstructed.	It may cause insufficiency of cooling (heating) capacity

## Pilot run

### • Preparation for test run

1. Power should not be turned on before completion of all installation works.
2. All lines are properly connected and all the electric wires are firmly connected.
3. Open the shut-off valve of thick and thin pipes
4. All the unnecessary materials, especially metal wire and thread, should be removed from the machine.

### • Method for test run

1. Turn on the power, press ON/OFF button on the remote control to start the air conditioner.
2. Press Mode button to select the required mode and check if the running is normal.

## 8. USE OF REMOTE CONTROLLER

- On first use, insert battery and ensure the Plus-n-Minus is in correct connection.
- Ensure that remote controller is pointed at the signal receiver without any obstruction; Do not make the remote controller fall off or throw it carelessly; Any liquid cannot flow into the remote controller; Do not put the remote controller near the high temperature objects or on the place exposed to direct sunlight or strong light.
- If the remote controller is unable to be operated, please reinsert the batteries after removing it for 30 second. If it is still unable to be operated, please replace new batteries. The useless batteries should be disposed as relevant national regulations.
- Do not mix use of new-and-used batteries or different type batteries, otherwise, the remote controller should be unable to be operated.
- If the remote controller is not used for a long time, please take out the batteries to prevent the remote controller from being damaged by the leaked fluid.
- Please understand that this type of remote controller is general type, including the entire function button. The specific function is subject to the function of A/C.

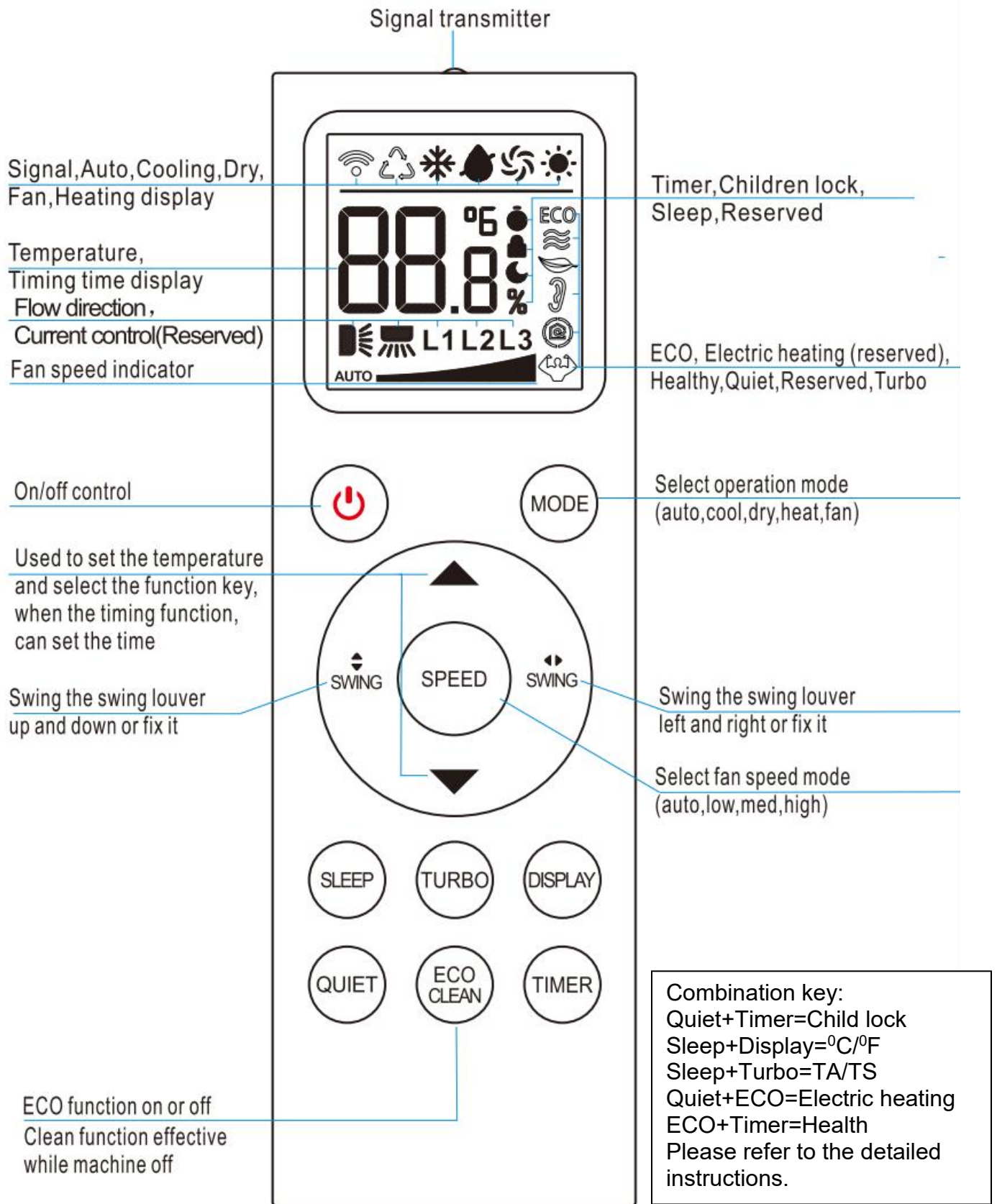

★ The picture of the remote control is for reference only, please refer to the actual product.

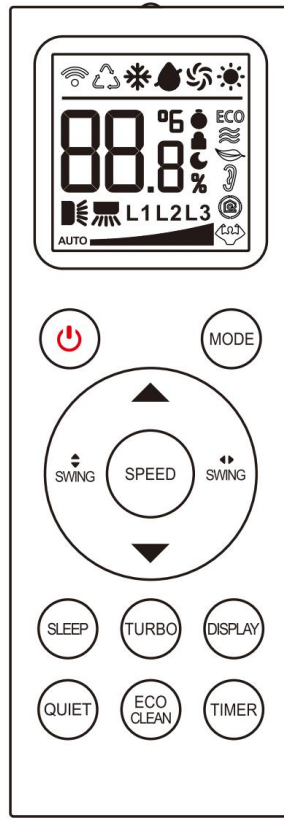

Button	Function
	On/Off control, for the air conditioning turned on or off.
	Pressing ECO to switch cyclically according to "ECO--STOP ECO--ECO"
	Cycle mode when this button is pressed as follows: AUTO--COOL--DRY--HEAT--FAN--AUTO
	(Temperature/Time) Press "△" once to set the temperature to rise by 1°C, press "▽" once to decrease the temperature by 1°C.  Temperature setting range is 16~32 °C Note: This button is invalid in DRY/FAN mode.
	Flap guide louver up-and-down when this button is pressed. Re-press to fix louver
	Button swing louver (internal louver): swing "swing louver" left-and-right or fix louver. (Only available for the A/C with this function)
Fan	High speed Medium speed Low speed Auto Auto speed TURBO QUIET
Display	When the air conditioner is on, press "DISPLAY" to turn on the room machine display and press again to turn off the air conditioner.
Sleep	A/C enters low speed mode by default under sleep mode. Fan speed is adjustable.

Cleaning	<ul style="list-style-type: none"> <li>• Only under remoter controller condition of power off, can it transmit “ auto clean” signal when this button is pressed to power on.</li> <li>• The remote control and indoor unit will display CL.</li> <li>• Press CLEAN or ON/OFF again to exit the automatic cleaning function. In automatic cleaning mode, the air conditioner will run for 10 to 15 minutes and then shut down automatically.</li> </ul>
TATS	<p>(only available for the A/C with this function)</p> <ul style="list-style-type: none"> <li>• Press the indoor machine once to display TS value (TS: setting temperature value), press again to display the indoor temperature TA value (current indoor environment temperature), and switch the cycle.</li> <li>• This function is optional, the electronic control panel does not support this function by default.</li> </ul>
Health	<p>(only available for the A/C with this function)</p> <ul style="list-style-type: none"> <li>• Press the ECO and TIMER keys to enable the health function. Then press again to cancel the feature.</li> <li>• Only by adding related auxiliary components (such as UV lamp and anion generator) can it be realized.This feature is optional and is not available by default.</li> </ul>
Timer	<ul style="list-style-type: none"> <li>• <math>\Delta/\nabla</math> (temp/timer) control button, each time press "<math>\Delta</math>" to set temperature rises 1 C, press "<math>\nabla</math>" to set temperature drops 1.</li> <li>• Temperature setting range is 16~32C.</li> </ul> <p>PS: The button is invalid when in clean and fan mode. Button "TIMER" should be operated with “time”. Specific operation is subject to button timer description. Pressing a key other than the open key will exit the timing display, but the timing is still valid.</p> <p>After the timed shutdown function is enabled, press the shutdown button to exit the timed shutdown function. After the timed startup function is enabled, press the power button to exit the timed startup function.</p>
$^{\circ}\text{C}/^{\circ}\text{F}$	When the air conditioner is on, press the SLEEP and DISPLAY keys at the same time to switch between the and $^{\circ}\text{C}/^{\circ}\text{F}$ displays. The default value is Celsius.
Child lock	Press the QUIET and TIMER keys at the same time to lock all the functions of the remote control,Press again to unlock.
Electric heating	<p>In the heating mode, press the ECO and QUIET keys to enable the electric heating function. <math>\approx</math> will be displayed on the remote control.</p> <p>The electric heating function is disabled by default.</p> <p>Note: Only heat pump air conditioners may be charged heating devices!</p>

## Replacement of Batteries

Remove the battery cover plate from the rear of the remote control, by sliding it in direction as the arrow.

Install the batteries according the direction (+ and -)shown on the Remote Control.

Reinstall the battery cover by sliding it into place.

 Use 2 pieces LRO3 AAA (1.5V) batteries.

Do not use rechargeable batteries.

Replace the old batteries with new ones of the same type when the display is no longer legible.

Do not dispose batteries as unsorted municipal waste.

Collection of such waste separately for special treatment is necessary.

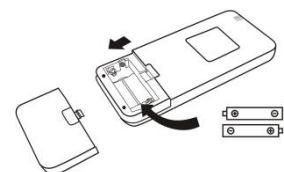

 For some model, each time when insert the batteries in the remote controller for the first time, you can set the Cooling only or Heating pump control type. As soon as you insert the batteries, turn off the remote controller, and operate as below.

1. Long press the **MODE** button, until the (❄️) icon flash, to set the Cooling only type.
2. Long press the **MODE** button, until the (☀️) icon flash, to set the Heating pump type.

NOTE: If you set the remote control in cooling mode, it will not be possible to activate the heating function in units with a heating pump. If you need to reset, take out the batteries and install again.



 For some model of remote controller, you can program the temperature display between °C and °F.



1. Press and hold the **TURBO** button over 5 seconds to get into the change mode;
2. Press and hold the **TURBO** button, until it switch to °C and °F;
3. Then release the pressing and wait for 5 seconds, the function will be selected.

NOTE:

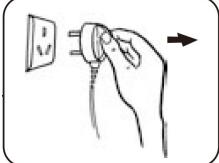
1. Direct the remote control toward the Air conditioner.
2. Check that there are no objects between the remote control and the Signal receptor in the indoor unit.
3. Never leave the remote control exposed to the rays of the sun.
4. Keep the remote control at a distance of at least 1m from the television or other electrical appliances.

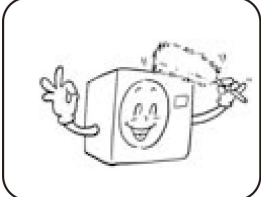
## 9. CLEANING AND MAINTENANCE

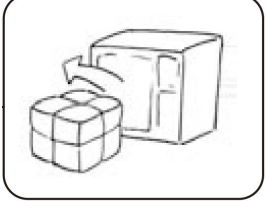
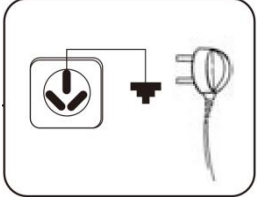
<p>The power must be shut off before maintenance.</p>	
<ul style="list-style-type: none"> <li>• Remove the filter screen</li> </ul> <p>Make sure the air conditioner is turned off. Gently push up the panel for small distance and tum over outward for a certain angle to open the panel. Lift up the filter screen and pull out toward yourself to remove.</p>	
<ul style="list-style-type: none"> <li>• Clean the filter screen</li> </ul> <p>Gently pat it or clean with vacuum cleaner. If the filter screen is too dirty, it can be washed by the solution containing small amount of neutral detergent. After washing, dry the filter screen and install it to the original location. Note: The filter screen should not be exposed to sunlight, dried by stove fire, or washed with hot water above 40°C. Otherwise it will be deformed.</p>	
<ul style="list-style-type: none"> <li>• Clean the air conditioner</li> </ul> <p>For safety purpose, the power plug must be unplugged before cleaning to avoid electric shock. Do not wash the air conditioner with water Wipe the machine with soft cloth. Do not wash the machine with volatile oil, gasoline, diluent, putty powder, etc. For fingerprint or oil contamination, please wash with household neutral detergent.</p>	

<p>• Before the using season</p> <p>Check if the air inlet and air outlet of indoor unit and outdoor unit are blocked.</p> <p>The protective cover of outdoor unit must be removed.</p> <p>Check if the installation base is corrosive or rusted.</p> <p>Check if the power cable and grounding wire are in normal condition.</p> <p>Check if the drain hose is bent, end is lifted, or is blocked.</p> <p>Before operation, check and make sure the air filter screen is well installed. If the machine is running without air filter screen, the air conditioner may be damaged by dust and foreign substances.</p>	 
<p>• After using season</p> <p>Shut down the air conditioner and pull out the power plug.</p> <p>Note: For common air conditioner, it will consume 5W power during standby status if the power plug is not pulled out.</p> <p>The standby power consumption of the machine marked with “*” is only 1W. 1W standby power consumption is measured in accordance with the enterprise standard Q/ZG119 “Measuring Method of Standby Power Consumption for Household Air Conditioner”.</p> <p>Please carefully clean and maintain the air filter screen and other parts.</p> <p>Cover the outdoor unit with plastic cloth to prevent the dust or waste from entering into the machine.</p>	

**Transportation, marking and storage for units that employ flammable refrigerants**

**General**

The following information is provided for units that employ flammable refrigerants.

**Transport of equipment containing flammable refrigerants**

Attention is drawn to the fact that additional transportation regulations may exist with respect to equipment containing flammable gas. The maximum number of pieces of equipment or the configuration of the equipment permitted to be transported together will be determined by the applicable transport regulations.

**Marking of equipment using signs**

Signs for similar appliances used in a work area are generally addressed by local regulations and give the minimum requirements for the provision of safety and/or health signs for a work location. All required signs are to be maintained and employers should ensure that employees receive suitable and sufficient instruction and training on the meaning of appropriate safety signs and the actions that need to be taken in connection with these signs.

The effectiveness of signs should not be diminished by too many signs being placed together. Any pictograms used should be as simple as possible and contain only essential details.

**Disposal of equipment using flammable refrigerants**

See national regulations.

**Storage of equipment/appliances**

The storage of the appliance should be in accordance with the applicable regulations or instructions, whichever is more stringent.

**Storage of packed (unsold) equipment**

Storage package protection should be constructed in such a way that mechanical damage to the equipment inside the package will not cause a leak of the refrigerant charge.

The maximum number of pieces of equipment permitted to be stored together will be determined by local regulations.

## 10. FAULT ANALYSIS

FAULT	ANALYSIS
After shutting down, the air conditioner cannot restart immediately.	If the user restarts the air conditioner when it is just stopped, the 3-minute protective timer of air conditioner will be automatically activated and the air conditioner will be restarted 3 minutes later.
If the air conditioner is shut down when it is in refrigerating mode, the wind supply should not be turned off immediately and wind deflector should not be closed immediately. (for machine type marked with *)	It is because that the air conditioner is executing the mould-proof operation and the indoor unit is running with low wind and wind deflector will be closed after 30 seconds.
No wind is supplied in the beginning of heating.	Before the heat exchanger of indoor unit is warm, stop wind supply to avoid blowing cold wind (for 2 to 5 minutes).
There is strange smell coming out when start-up.	It is because that the smoke and smell from cosmetics, wall or furniture is attached on the air conditioner and is dissipated by wind blowing.
Water flow sound can be heard during operation of the air conditioner	It is the flowing sound of internal refrigerant of the air conditioner
Crackle can be heard after starting or stopping the heating or refrigerating	It is caused by the thermal expansion and extraction.

Before contacting the service department, please check the following items, which may save your time and expense.

“Malfunction”	Analysis on the “Malfunction”
Air conditioner is unable to run.	<ul style="list-style-type: none"> <li>① Check if power is failed.</li> <li>② Check if power is connected.</li> <li>③ Check if Timing ON/OFF function is set.</li> <li>④ Check if the voltage is too high or too low.</li> <li>⑤ Check if the residual current circuit breaker is switched off.</li> </ul>
Cooling (heating) effect is not good.	<ul style="list-style-type: none"> <li>① Check if the set temperature is OK.</li> <li>② Check if the air inlet and outlet of indoor and outdoor unit are blocked.</li> <li>③ Check if the air filter screen is blocked by too much dirt.</li> <li>④ Check if all the doors and windows are closed.</li> <li>⑤ Check if there are any heat resources.</li> </ul>
Remote control is not functional.	<ul style="list-style-type: none"> <li>① When the remote control is exposed to direct sunlight or strong light, the remote signal may not be received. In this case, please block out the sunlight or dim the lighting.</li> <li>② Check if it is within the reception range and if any obstacles.</li> <li>③ Check if the battery voltage is sufficient. Or you should replace with new batteries.</li> <li>④ If the remote control display is not clear, please replace with new batteries.</li> </ul>

In case of following situations, please stop operation immediately, shut off power, and contact our dealers or authorized service center.

- The fuse always bum out and electric switch is always disconnected.
- Electric wire is abnormally heated or the wire insulation is broken.
- Other abnormal status.

## 11. DISPOSAL

- Disposal of the appliance



■ A crossed-out wheellie bin icon means: Batteries and rechargeable batteries, electrical or electronic devices must not be disposed of with household waste. They may contain substances that are harmful to the environment and human health.

Consumers must dispose of waste electrical devices, spent portable batteries and rechargeable batteries separately from household waste at an official collection point to ensure that these items are processed correctly. Information on returning these items is available from the seller. Sellers are required to accept these items free of charge.

Batteries and rechargeable batteries, which are not permanently installed in waste electrical devices, must be removed prior to disposal and must be disposed of separately.

Lithium batteries and battery packs in all systems must only be returned to a collection point when discharged.

Batteries must always be protected against short circuits by covering the poles with adhesive tape.

All end users are responsible for deleting any personal data stored on waste devices prior to their disposal.

- Disposal of the packaging



The packaging consists of cardboard and correspondingly marked plastics that can be recycled. Make these materials available for recycling.

## 12. DECLARATION OF CONFORMITY



SODILOG SAS  
4 RUE CURIE, CS 91617 68016 COLMAR CEDEX FRANCE

Declares that the machines:

AIR CONDITIONER

Model: FCW2600PAP-A, FCW3500PAP-A

Serial No.: 20260320775-20260321034 /20260321035-20260321374

Complies with the provisions of the Directive:  
COMMISSION REGULATION (EU) No 206/2012  
COMMISSION DELEGATED REGULATION (EU) No 626/2011  
Directive LVD 2014/35/EU  
Directive EMC 2014/30/EU  
Directive RED 2014/53/EU  
ROHS Directive(EU)2015/863 amending 2011/65/EU

Also complies with European standards, with national standards and the following technical provisions:

EN 60335-2-40: 2003 +A11+A12+A1+A2+A13  
EN 60335-1:2012+A11+A13+A1+A14+A2+A15  
EN 62233: 2008  
EN 61000-3-3:2013+A1:2019+A2:2021  
ENIEC55014-1:2021  
EN IEC55014-2:2021  
EN IEC 61000-3-2:2019+A1:2021  
EN 301 489-1 V2.2.3; EN301 489-17 V3.2.4  
EN 300 328 V2.2.2; EN IEC62311:2020

The people name holding the technical file: Mr. Mark

COLMAR CEDEX 05/02/2026

Jacques Masson / PDG

## 13. WARRANTY

The manufacturer guarantees the product against defects in material and workmanship for a period of 5 years from the date of the original purchase. It can be extended by one year if the user subscribes to website of myswap. The warranty only applies if the product is for household use. The warranty does not cover breakdowns due to normal wear and tear.

The manufacturer agrees to replace parts identified as defective by the designated distributor. The manufacturer does not accept responsibility for the replacement of the machine, in whole or in part, and/or ensuing damage.

### **The warranty does not cover breakdowns due to:**

- insufficient maintenance.
- abnormal assembly, adjustment or operations of the product.
- parts subject to normal wear and tear.

### **The warranty does not extend to:**

- shipping and packaging costs.
- using the tool for a purpose other than that for which it was designed.
- the use and maintenance of the machine done in a manner not described in the user manual.

Due to our policy of continuous product improvement, we reserve the right to alter or change specifications without notice. Consequently, the product may be different from the information contained therein, but a modification will be undertaken without notice if it is recognized as an improvement of the preceding characteristic.

### **READ THE MANUAL CAREFULLY BEFORE USING THE MACHINE.**

When ordering spare parts, please indicate the part number or code, you can find this in the spare parts list in this manual. Keep the purchase receipt; without it, the warranty is invalid. To help you with your product, we invite you to contact us by phone or via our website:

**+33 (0)9.70.75.30.30**

**<https://services.swap-europe.com/contact>**

You must create a "ticket" via the web platform.

- Register or create your account.
- Indicate the reference of the tool.
- Choose the subject of your request.
- Describe your problem.

Attach these files: invoice or sales receipt, photo of the identification plate (serial number), photo of the part you need (for example: pins on the transformer plug which are broken).



**swap**

## 14. PRODUCT FAILURE

### WHAT TO DO IF MY MACHINE BREAKS DOWN?

#### If you bought your product in a store:

- Make sure that your machine is complete with all accessories supplied, and clean! If this is not the case, the repairer will refuse the machine.
- Go to the store with the complete machine and with the receipt or invoice.

#### If you bought your product on a website:

- Make sure that your machine is complete with all accessories supplied, and clean! If this is not the case, the repairer will refuse the machine.
- Create a SWAP-Europe service ticket on the site: <https://services.swap-europe.com> When making the request on SWAP-Europe, you must attach the invoice and the photo of the nameplate (serial number).

Contact the repair station to make sure it is available before dropping off the machine.

Go to the repair station with the complete machine packed, accompanied by the purchase invoice and the station support sheet downloadable after the service request is completed on the SWAP-Europe site

**Please keep your original packaging to allow for after-sales service returns or pack your machine with a similar cardboard box of the same dimensions.**

For any question concerning our after-sales service you can make a request on our website <https://services.swap-europe.com>

Our hotline remains available at +33 (9) 70 75 30 30.



## 15. WARRANTY EXCLUSIONS

### THE WARRANTY DOES NOT COVER:

- Start-up and setting up of the product.
- Damage resulting from normal wear and tear of the product.
- Damage resulting from improper use of the product.
- Damage resulting from assembly or start-up not in accordance with the user manual.
- Periodic and standard maintenance events.
- Actions of modification and dismantling that directly void the warranty.
- Products whose original authentication marking (brand, serial number) has been degraded, altered or withdrawn.
- Replacement of consumables.
- The use of non-original parts.
- Breakage of parts following impacts or projections.
- Accessories breakdowns.
- Defects and their consequences linked to any external cause.
- Loss of components and loss due to insufficient screwing.
- Cutting components and any damage related to the loosening of parts.
- Overload or overheating.
- Poor power supply quality: faulty voltage, voltage error, etc.
- Damages resulting from the deprivation of enjoyment of the product during the time necessary for repairs and more generally the costs related to the immobilization of the product.
- The costs of a second opinion established by a third party following an estimate by a SWAP-Europe repair station
- The use of a product which would show a defect or a breakage which was not the subject of an immediate report and/or repair with the services of SWAP-Europe.
- Deterioration linked to transport and storage\*.

\* In accordance with transport legislation, damage related to transport must be declared to carriers within 48 hours maximum after observation by registered letter with acknowledgement of receipt. This document is a supplement to your notice, a non-exhaustive list.

**Attention:** all orders must be checked in the presence of the delivery person. In case of refusal by the delivery person, it you must simply refuse the delivery and notify your refusal.

**Reminder:** the reserves do not exclude the notification by registered letter with acknowledgement within 72 hours.

#### **Information:**

Thermal devices must be wintered each season (service available on the SWAP-Europe site). Batteries must be charged before being stored.

# FEIDER



CE

SODILOG SAS  
4 RUE CURIE, CS 91617 68016 COLMAR CEDEX FRANCE  
[www.sodilog.com](http://www.sodilog.com)  
Made in PRC